

Heavy Duty Door Closer DCI50N

Matches LCN4040 Hole Pattern

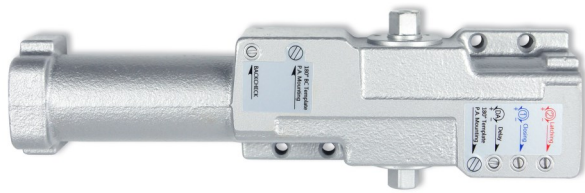

DESCRIPTION	PRODUCT CODE	CASE
Door Closer, Matches Norton 1601 Hole Pattern, Adjustable 1-6	DC-I50N	2
Cush and Stop Hold-Open Arm	DC-CSTI50	6
Drop Plate Parallel Arm Installation	DC-PDP150	6
Drop Plate Regular Jam Installation	DC-RDP150	6
Drop Plate Top Jam Installation	DC-TDP150	6

Finishes

SP Silver Powder Coat
FBL Flat Black

Door Handing

Reversible, non-handed for RH or LH swing doors

Adjustable Power Size

1-6

Features

Adjustable closing and latching speed
Adjustable backcheck
Adjustable delay
Thermo-constant valve
Rack-and-pinion

Certifications

ANSI Grade I A156.4 G1
UL Listed
ADA Compliant A117.1

Applications

Standard Arm
Top Jamb
Parallel Arm

Door Weight

Up to 180 lbs.

Materials

One-piece cast iron
Steel Arm
Plastic Cover (included)

DC-150N

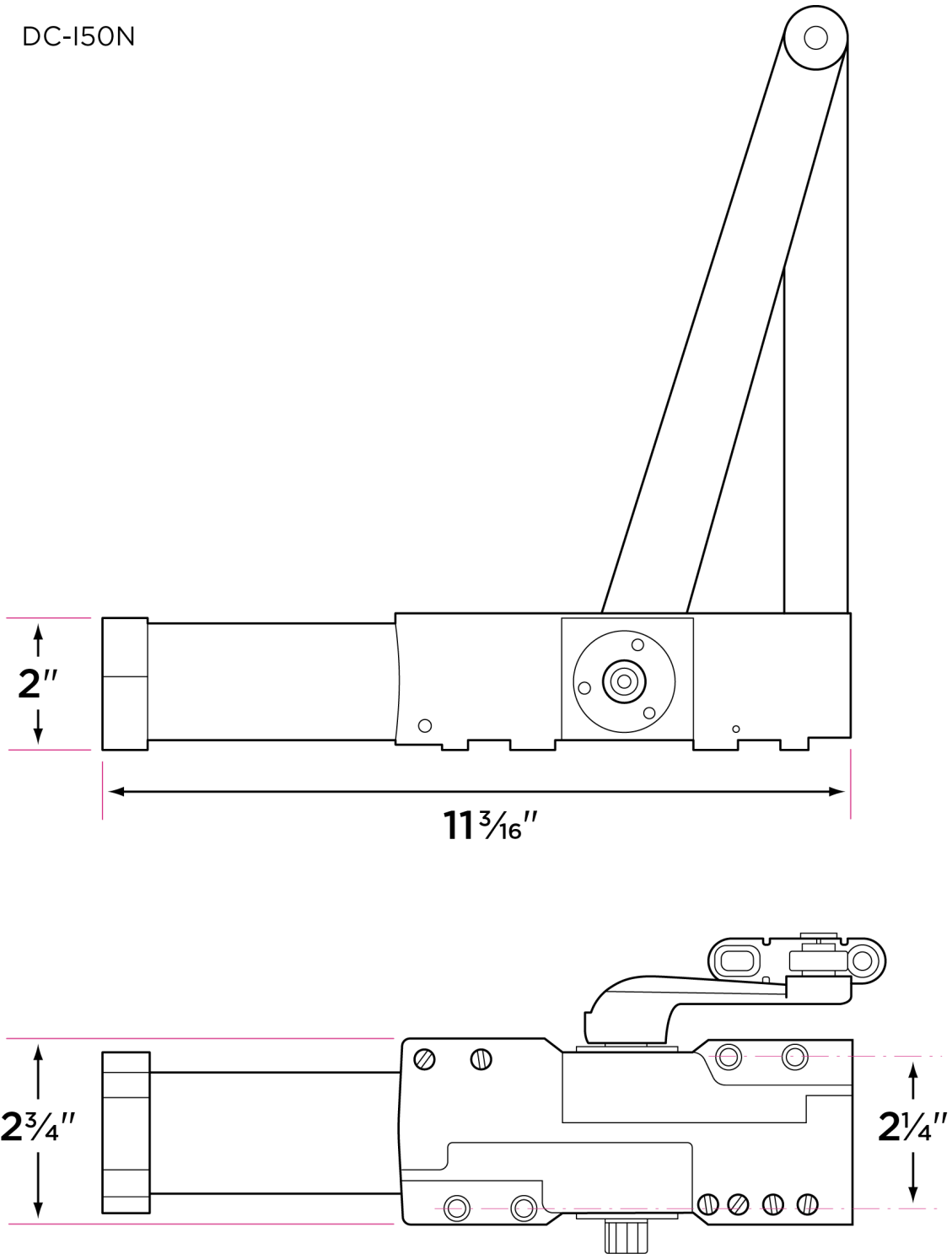

DC-TDP150

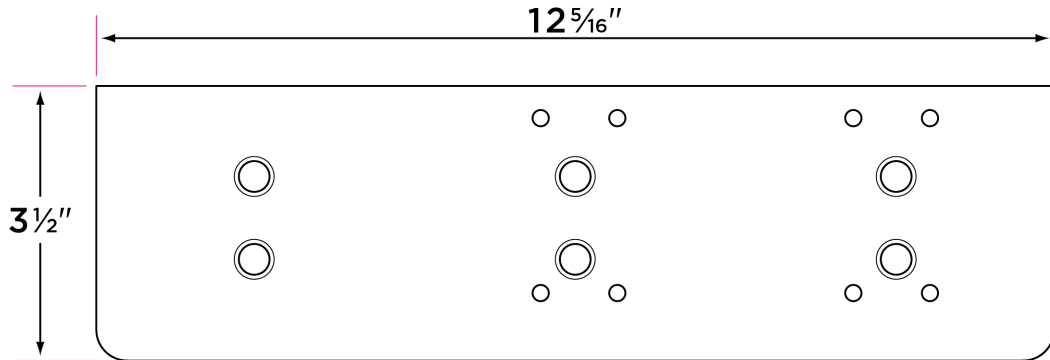

DC-PDP150

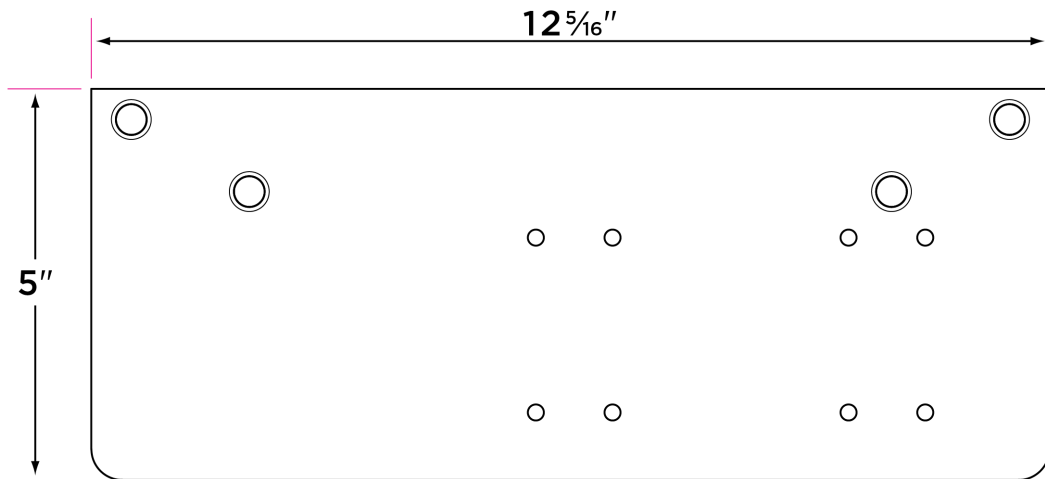

DC-RDP15

